

CWTFA-TC

17.9" x 18.5" x 9.0"
(45.5cm x 47.0cm x 22.9cm)



- Models are space saving 9" wide (22.9cm)
- Accepts thermal carafe up to 8.5" (21.6 cm) tall
- All stainless steel construction
- Hot water faucet
- Pourover feature
- SplashGard® funnel deflects hot liquids away from the hand
- Use in quick turn environments where high quality coffee is continuously refreshed

 Servers and airpots sold separately

Agency:



Specifications

Product #: 12950.0362
Water Access: Plumbed
Finish: Stainless
Funnel: Black Plastic
Faucet: Upper

Additional Features

Electrical & Capacity

Volts	Amps	Watts	Cord Attached	Plug Type	8oz cups/hr 236ml cups/hr	Input H ² O Temp.	Phase	# Wires plus Ground	Hertz
220-240	8.6-9.5	1900-2300	Yes	EURO 16A	86	60°F (15.5°C)	1	2	50-60

Plumbing Requirements

PSI	kPa	Fitting Supplied	Water Flow Required (GPM)
20-90	138-621	1/4" Male Flare Fitting	-

CAD Drawings

2D	Revit	KLC
●		



BUNN® reserves the right to change specifications and product design without notice. Such revisions do not entitle the buyer to corresponding changes, improvements, additions or replacements for previously purchased equipment. For most current specifications and other info visit bunn.com.

Created on:
07/14/2016

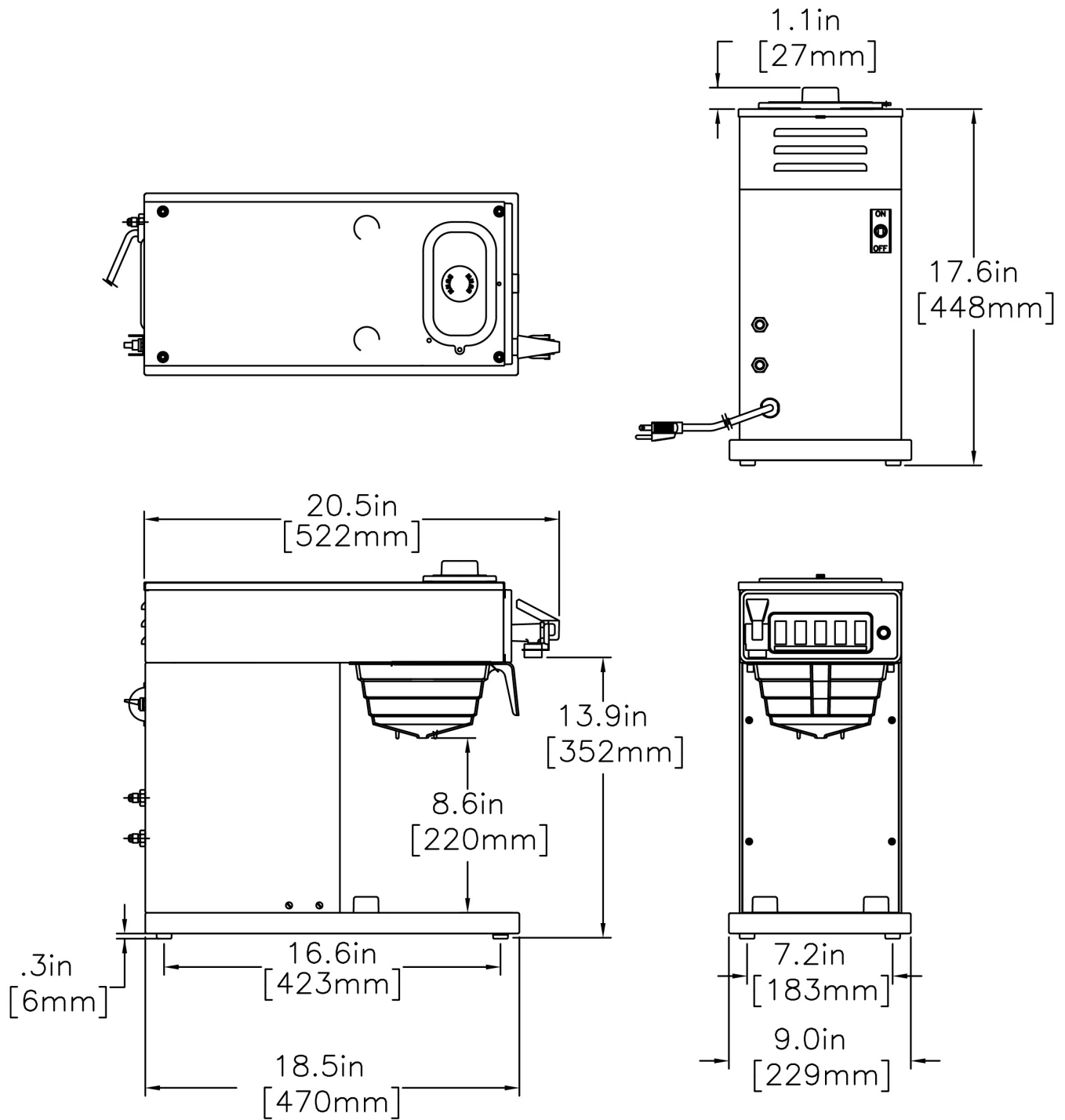

	Unit			Shipping				
	Width	Height	Depth	Width	Height	Depth	Weight	Volume
English	9.0 in.	17.9 in.	18.5 in.	-	-	-	31.000 lbs	3.807 ft ³
Metric	22.9 cm	45.5 cm	47.0 cm	-	-	-	14.062 kgs	0.108 m ³



BUNN® reserves the right to change specifications and product design without notice. Such revisions do not entitle the buyer to corresponding changes, improvements, additions or replacements for previously purchased equipment. For most current specifications and other info visit bunn.com.

Created on:
07/14/2016

Related Products & Accessories: CWTFA-TC(12950.0362)



FILTERS,REGULAR1M
500/2 50/CL

Product #: 20115.0000



WATER FILTER
SYSTEM, EQ-17-TL

Product #: 30200.1000



BUNN® reserves the right to change specifications and product design without notice. Such revisions do not entitle the buyer to corresponding changes, improvements, additions or replacements for previously purchased equipment. For most current specifications and other info visit bunn.com.

Created on:
07/14/2016

Serving & Holding Options: CWTFA-TC(12950.0362)



THERMAL CARAFE, BLK
1.9L 12PK

Product #:36029.0000



THERMAL CARAFE, BLK
1.9L 1PK

Product #:36029.0001



THERMAL CARAFE, ORN
1.9L 12PK

Product #:36252.0000



THERMAL CARAFE, ORN
1.9L 1PK

Product #:36252.0001



CARAFE, SST 1.9L SHRT
BLK 1/

Product #:40163.0000



CARAFE, SST 1.9L SHRT
ORN 1/

Product #:40163.0001



CARAFE, SST 1.9L SHRT
BLK 12/

Product #:40163.0100



CARAFE, SST 1.9L SHRT
ORN 12/

Product #:40163.0101



BUNN® reserves the right to change specifications and product design without notice. Such revisions do not entitle the buyer to corresponding changes, improvements, additions or replacements for previously purchased equipment. For most current specifications and other info visit bunn.com.

Created on:
07/14/2016